

Optimal® diagonaalsahk



Optimal® diagonaalsahk on mõeldud kergliiklus- ja sõiduteede ning suurte territooriumite lumest puhastamiseks. Saha löökide leevendusmehhanism vähendab oluliselt haakeseadme kahjustamise riski.

Leevendusmehhanism võimaldab sahal takistusega kokkupõrkel kerkida ja liikuda tahapoole, mis on piisav liikumisruum suuremate takistuste ületamiseks.

Suurema liikumiskiirusega töötamisel vähendab leevendusmehhanism saha üles-alla liikumist.

Sile lõiketera on standardvarustuses, hammastera saab tellida lisavarustusena.

Saha haakimiseks pakume erinevaid kiirhaake lahendusi.

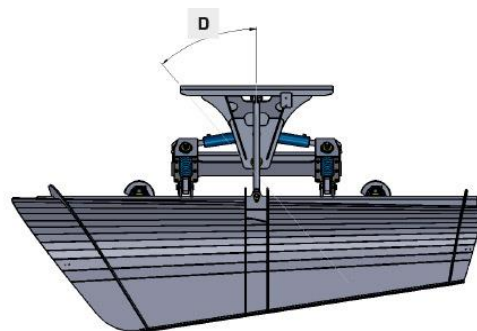
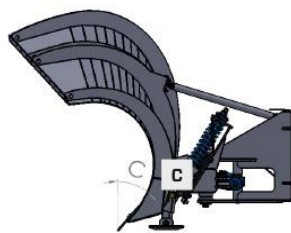
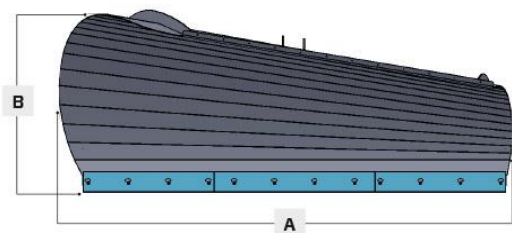

Tehnilised andmed

Mudel	Mõõde A	Mõõde B	Tera kaldenurk C	Saha pöördenurk D	Kaal
AA320	3200 mm	1350 mm	40°	+/- 41°	830 kg
AA370	3700 mm	1400 mm	40°	+/- 41°	950 kg

